

REMOTE METAL DETECTING ROBOT

Somula Anusha ¹, Dr .M. J C Prasad ²

1. Post Graduate scholar, Malla Reddy Engineering College, Kompally, Ranga Reddy, Telangana.
2. Professor, Department of Electronics and Communication Engineering, Malla Reddy Engineering College, Hyderabad-500100, India

Abstract— To develop a robotic vehicle that can sense metals ahead of it on its path similar to sensing land mines. Metal detector robot using Arduino uno this robot is designed for metal detection in places where human being can't reach easily. Metal detector robot detects metal through metal detector sensor. It detects metals coming to it ways. Wherever it goes, it keeps detecting metal. In case of metal detection, a sound will be produced at the control room or receiver side. This research will give you brief idea about how metal detector robot works.

Keywords— robotic vehicle, metal detection, arduino uno, sensor.

I. INTRODUCTION

Metal detectors are fascination machine; this research is to develop a robotic vehicle that can sense metals ahead of it on its path similar to sensing land mines. It consists of a proximity sensor that detects the metals ahead of it and image in front of the surrounding is sent to the mail. Arduino uno is used for the desired operation. A proximity sensor is mounted on the robot body and its operation is carried out automatically on sensing any metal underneath. As soon as the robot senses this metal it sends the alert. This alerts the operator of a possible metal ahead on its path. A metal detector is a device which responds to metal that may not be readily apparent. The simplest form of a metal detector is the proximity sensor which detects the metal when it is close to some target and it sends the control signal. A highly sensitive proximity sensor and a zigbee is fixed to this robot. When the robot is moving on a surface, proximity sensor detects the metal when the metal is detected the zigbee sends an alert. The rest of the paper is organized as follows: Section 2 represents the related work, Section 3 represents the background and motivation, In Section 4 we present our approach, In Section 5 we present our simulated results, Section 6 concludes the paper.

II. Related Work

The first industrial metal detectors were developed in the 1960s and were used extensively for mining and other industrial applications [1]. Uses include de-mining (the detection of land mines), the detection of weapons such as knives and guns, especially in airport security, geophysical prospecting, archaeology and treasure hunting. Metal detectors are also used in the construction industry to detect steel reinforcing bars in concrete and pipes and wires buried in walls and floors.

II. Background and Motivation

In the present-day scenario, we are facing many threats by bomb blasts. We have existing methods like human surveillance for bomb detection so our research aim is to prepare an unmanned vehicle which detects metal as bombs are usually made of metal.

III. Proposed Approach

In this research we develop a robotic vehicle that can sense metals ahead of it on its path similar to sensing land mines. Arduino Uno is a microcontroller board based on 8-bit ATmega328P microcontroller. Along with ATmega328P, it consists other components such as crystal oscillator, serial communication, voltage regulator, etc. to support the microcontroller [2]. Arduino Uno has 14 digital input/output pins (out of which 6 can be used as PWM outputs), 6 analog input pins, a USB connection, A Power barrel jack and a reset button.

Zigbee works under the IEEE 802.15.4/ZigBee stand with 2.4GHz [3]. Interoperability and worldwide usability needed for only two major modes (Tx/Rx or sleep). Low data rate, low cost and ultra-low power consumption.

The L293D is an integrated circuit motor driver that can be used for simultaneous, bidirectional control dc motors. L293D is a dual H-Bridge motor driver. DC motors which can be controlled in both clockwise and counter clockwise direction.

Transmitter Section

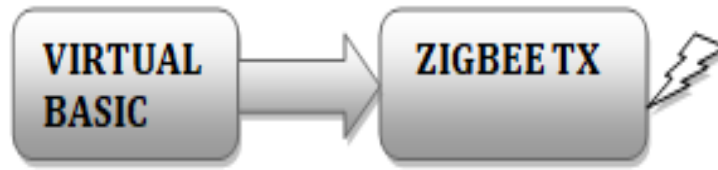

Robot (Receiver Section)

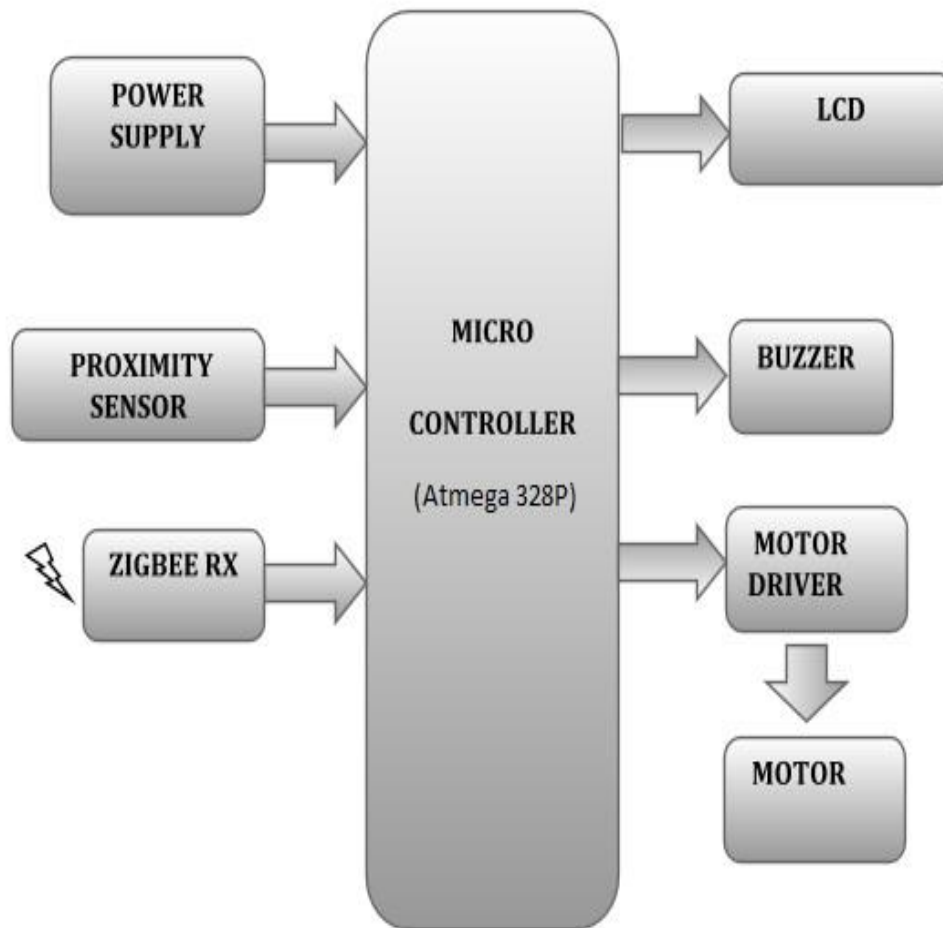

An inductive proximity sensor is a type of non-contact that is used to detect the position of metal objects. Inductive proximity sensors enable the detection, without contact, of metal objects at distances of up to 60 mm, high operating rates, fast response, excellent resistance to industrial environments, solid state technology: no moving parts, therefore service life of sensor independent of the number of operating cycles. Inductive proximity sensors are solely for the detection of metal objects. They basically comprise an oscillator whose windings constitute the sensing face.

An alternating magnetic field is generated in front of these windings. When a metal object is placed within the magnetic field generated by the sensor, the resulting currents induced from an additional load and the oscillation causes.

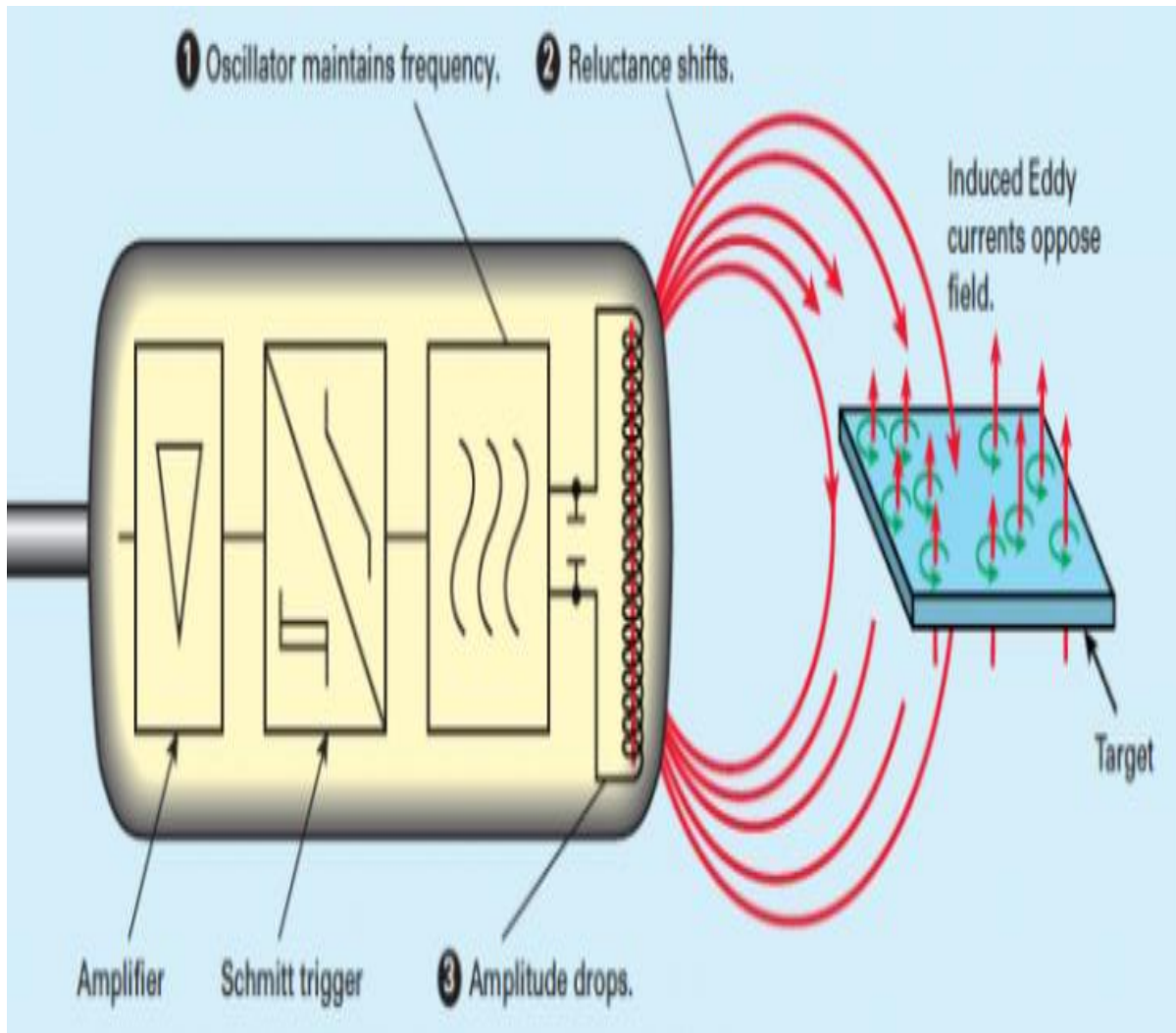

IV. Simulated Result

This project works with the proximity sensor as its metal detector. When the metal is detected, it alerts the operator. The signal alert is also sent to the arduino uno. The arduino uno directly cannot drive the motors. So arduino uno sends the output to the L293 motor driver. This motor driver runs the motors. There are two DC motors. The motors will drive the robot. It consists of a proximity sensor. Whenever the robot finds any metal in its path it stops there and the proximity sensor sends the alert to the control unit. Further the project can be enhanced by live streaming so that the movements of the robot can controlled remotely by watching it on a screen.

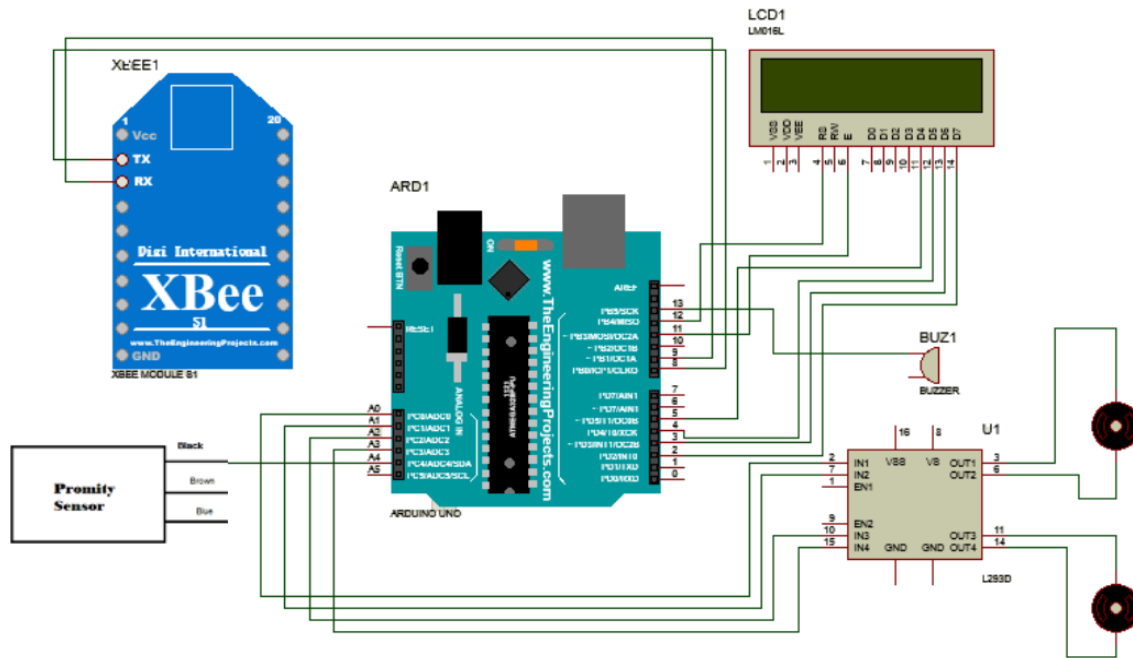

It is most advanced technology. It is of low cost. By using this technology, we can detect the bomb as early as possible and dismantle it easily so that we can easily save the life of the human beings. We can use better sensors and high-end modules to detect meals more precisely.

V. Conclusion

This research presents a metal detecting robot using Arduino uno and zigbee. The mine sensor worked at a constant speed without any problem despite its extension, meeting the specification required for the mine detection sensor. It contributed to the improvement of detection rate, while enhancing the operability as evidenced by completion of all the detection work as scheduled. The tests demonstrated that the robot would not pose any performance problem for installation of the mine detection sensor. On the other hand, however, the tests also clearly indicated areas where improvement, modification, specification change and additional features to the robot are required to serve better for the intended purpose. Valuable data and hints were obtained in connection with such issues as control method with the mine detection robot tilted, merits and drawbacks of mounting the sensor, cost, handling the cable between the robot and support vehicle, maintainability, serviceability and easiness of adjustments. These issues became identified as a result of our engineers conducting both the domestic tests and the overseas tests by themselves, and in this respect the findings were all the more practical.

REFERENCES

- [1] G. Overton and C. Moreland, "History of the Metal Detector", *Inside the Metal Detector*. 2016.
- [2] W. P. Osborne, "Download, Install, and test the Integrated Development Environment", *Learn to Program in Arduino™C*. 2017.
- [3] R. Faludi, "Zigbee and Arduino", *Building Wireless Sensor Networks*. edition 1. 2010.